

Limit Switch liquiphant T FTL 260

**Vibration limit switch for liquids
The maintenance-free alternative to float
switches**



Application

The Liquiphant is a limit switch for liquid level detection in storage tanks, tanks with agitators, and piping.

It can be used as an alternative to float switches as well as in applications where build-up, turbulence, liquid flow and gas bubbles are present.

Features and Benefits

- Small, slender design: low space requirement, easy mounting in places with limited access
- Stainless steel housing: rugged
- Switching status and external testing: simple control
- Plug connection: low-cost connection

Measuring System

The Liquiphant FTL 260 is a compact limit switch, to which miniature contactors, magnetic valves and programmable logic controllers (PLC) can be directly connected.

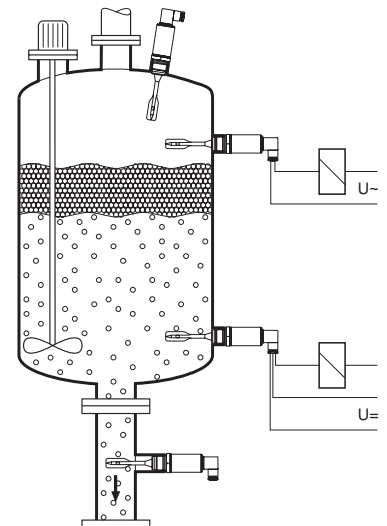

Endress + Hauser

The Power of Know How



Function and Dimensions

The symmetrical vibrating fork is excited to its resonant frequency which changes when the fork is submerged in liquid. The change is registered by the electronics, which actuate an electronic switch.

The Liquiphant FTL 260 can be operated in both minimum or maximum fail-safe mode, i.e. the electronic switch opens on reaching the limit value, in cases of fault or a loss of power.

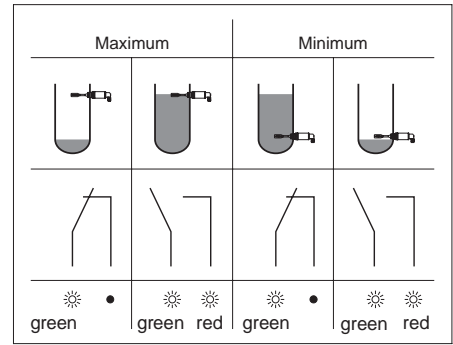
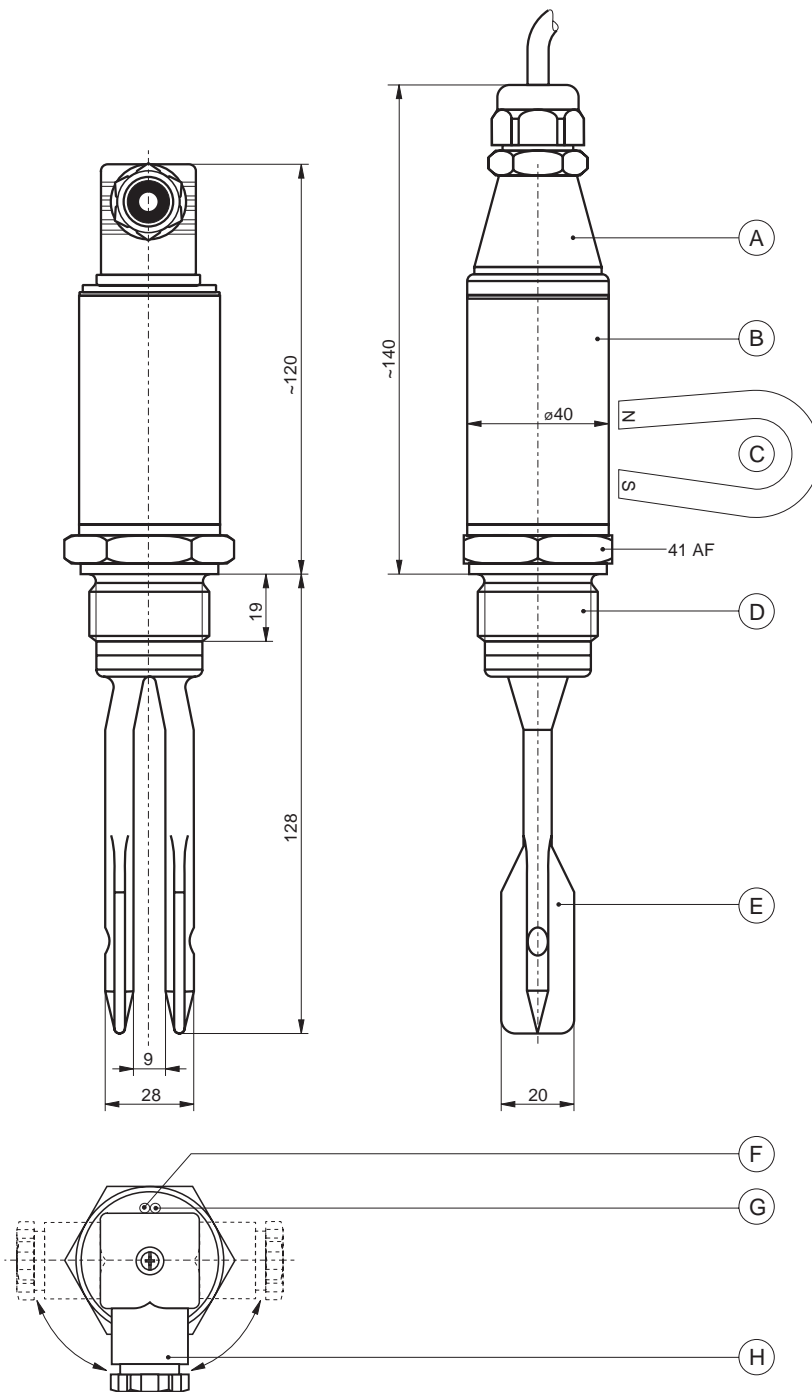

Diagram showing the function of the **electronic** switch and LED depending on the level and fail-safe mode



- A Electrical connection with a standard plug and with cable gland Pg 11 (IP 65 / 67) or permanently attached cable (IP 68). The fail-safe mode is determined by the way the connection is wired
- B The stainless steel housing protects the potted electronics
- C The switching function can be checked externally by placing a magnet on the housing
- D Process connection versions:
G 1 A (parallel)
1 - 1 1/2 NPT (tapered)
R 1 (tapered)
in stainless steel
- E Vibrating fork in solid stainless steel
- F Green LED "Operating mode"
- G Red LED to indicate switching mode "Circuit open"
- H The plug housing can also be fitted offset by $\pm 90^\circ$

Dimensions in mm
100 mm = 3.94 in
1 in = 25.4 mm

Installation

The Liquiphant FTL 260 can be mounted in any position in a tank or in a section of piping.

- A Vertical mounting
- B Horizontal mounting
- C Mounting in a 1" nozzle
(A to C for the entire range of viscosities up to 10000 mm²/s)
- D Flanged mounting in a nozzle
(Liquiphant screwed into blind flange),
Range of viscosities at DN 50 up to max. 2000 mm²/s
- E For easy mounting in limited space:
mount with 41 AF box spanner
(Endress+Hauser accessory)

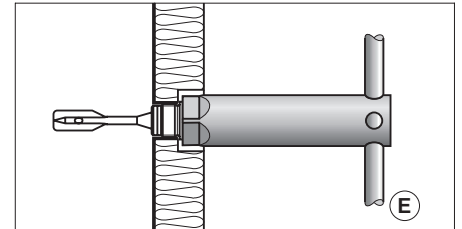
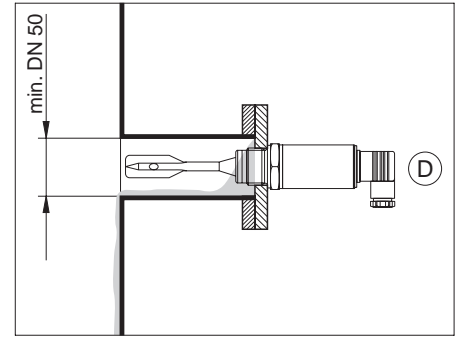
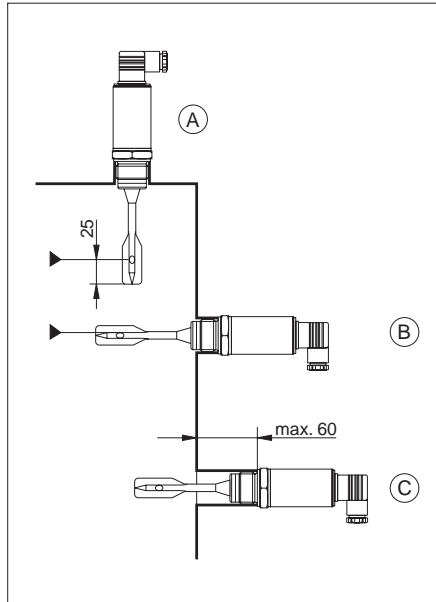

► Switchpoint

Electrical Connection

Electrical connection depending on version and fail-safe mode

Max. = maximum fail-safe mode

Min. = minimum fail-safe mode

② = cable connection

BU = blue
BK = black
BN = brown
GNYE = green/yellow

① = plug connection

R = external load

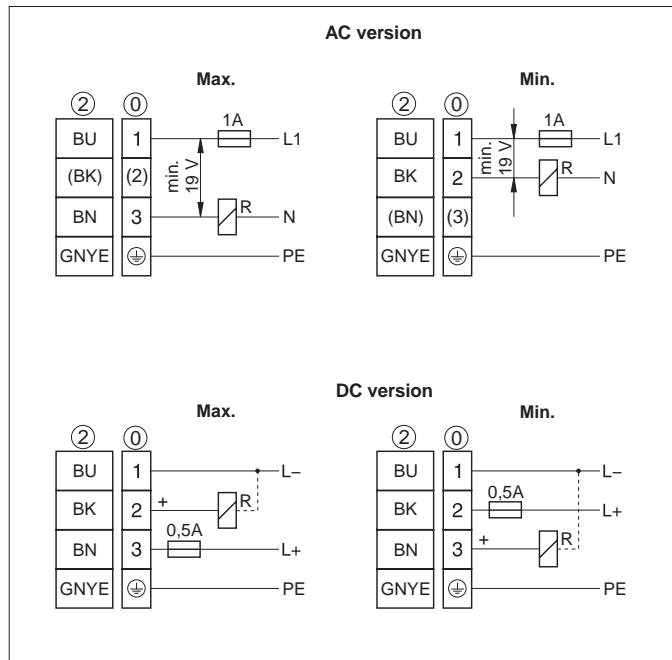

AC Version

A load must be connected in series with the Liquiphant, whereby:

- the voltage drop across the Liquiphant in closed mode (ON) may be up to 12 V
- a minimum terminal voltage of 19 V is required for the unit to switch correctly (check in particular for a low line voltage).

In open mode (OFF) a residual current of max. 3.8 mA flows.

DC Version

Recommended when used with programmable logic controllers (PLC). Positive signal at the switching output of the Liquiphant (PNP).

The fail-safe mode is determined by the way the output is connected up.

FTL 260 Limit switch

Certificate

- 0 Standard (non-certified)
- 3 CSA General purpose

Process Connection

- 0 G 1 A (parallel)
- 1 1 - 11½ NPT (tapered)
- 2 R 1 (tapered)

Electronics

- 1 Two-wire AC connection 19 ... 253 V
- 2 Three-wire DC connection 10 ... 55 V

Version

- 0 With plug connection (cable gland Pg 11)
- 2 With 5 m cable

FTL 260 - [] [] [] [] Full product designation

Product structure

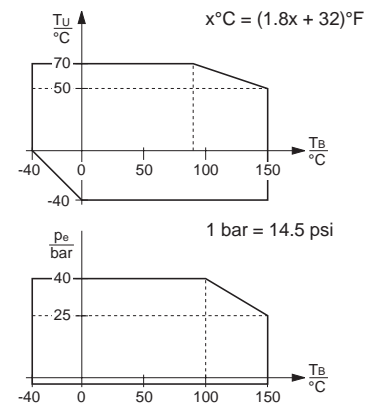

Top graph: Permissible values for ambient temperature T_U at housing are dependent on the operating temperature T_B in the tank

Bottom graph: Permissible values for operating pressure p_e are dependent on the operating temperature T_B in the tank

Technical Data

Output AC version

Power supply	Voltage at terminals 19 ... 253 V, 50 / 60 Hz, current consumption (stand-by) max. 4 mA
Connectable load (load switched over thyristor directly into the power supply circuit)	Short-term (40 ms): max. 1.5 A; max. 375 VA at 250 V or max. 36 VA at 24 V (no short-circuit protection) Continuous: max. 87 VA at 250 V (350 mA), max. 8.4 VA at 24 V (350 mA) min. 2.5 VA at 250 V (10 mA), min. 0.5 VA at 24 V (20 mA) Voltage drop across FTL 260: max. 12 V Residual current: max. 4 mA with open thyristor (stand-by)

Output DC version

Power supply	10 ... 55 V, ripple max. 1.7 V, 0 ... 400 Hz, current consumption max. 15 mA, reverse polarity protection
Connectable load (The load is switched via PNP-transistor)	Short-term (1 ms): max. 1 A, max. 55 V (overload and short-circuit protection) Continuous: max. 350 mA max. 0.5 μ F at 55 V, max. 1 μ F at 24 V Residual voltage: < 3 V (with closed transistor) Residual current: < 100 μ A (with open transistor)

Output

Fail-safe mode	Minimum or maximum fail-safe mode, depending on load connection
Signal failure	Output open
Switching time	Approx. 0.5 s when covered, approx. 1.0 s when free
Hysteresis	Approx. 4 mm with vertical mounting

Process conditions

Orientation	As required
Ambient temperature	-40 °C ... +70 °C, see also graphs on Page 3
Temperature of product	-40 °C ... +150 °C, see also graphs on Page 3
Operating pressure p_e	- 1 bar ... +40 bar, see also graphs on Page 3
Storage temperature	-40 °C ... +85 °C
Climatic protection	Climatic protection to IEC 68, Part 2-38, Fig. 2a
Ingress protection to EN 60529	With plug (cable gland Pg 11) IP 65 / IP 67, with cable IP 68 (24 h, 1.5 m)
Electromagnetic Compatibility	By attaching the CE Mark, Endress+Hauser confirms that the Liquiphant FTL 260 fulfils all legal requirements of EC directives. Interference immunity to EN 50082-2 (field strength 10 V/m), Interference emission to EN 50081-1
Density ρ of product	min. 0,7 g/cm ³
Viscosity ν of product	up to 10000 mm ² /s

Mechanical construction

Design	Compact unit, mounted using a 41 AF box spanner or open end spanner
Dimensions	See dimensional sketch on Page 2
Weight	Approx. 0.45 kg
Materials	Process connection and vibrating fork: stainless steel 1.4571, 1.4581 (AISI 316 Ti) Housing: stainless steel 1.4404 (AISI 316 L), Housing cover: PPSU Plug: PA, Plug seal: elastomer Flat seal ring for process connection G 1 A: elastomer-fibre, asbestos-free, resistant to oils, solvents, vapours, weak acids and alkalis
Process connections	Parallel thread G 1 A to DIN ISO 228/1 with flat seal 33x39 to DIN 7603 Tapered thread 1 - 1 1/2 NPT to ANSI B 1.20.1 Tapered thread R 1 to DIN 2999 Part 1
Electrical connection	4-pole plug connection to DIN 43650-A, ISO 4400 with cable gland Pg 11, for cable diameters 6 to 9 mm, max. wire cross section 1,5 mm ² or 5 m permanently attached cable, 4 x 0.75 mm ²

Ordering

Product structure	See product structure on Page 3
Accessories	Box spanner 41 AF - order number 942 667-0000 Test magnet - order number 016920-0000
Supplementary Documentation	System Information "Liquiphant" SI 007F/00/e

